

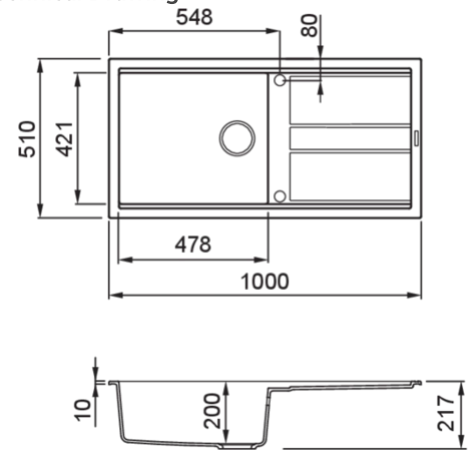

BEST 10 XL

Technical Drawing



0	
Description	1-bowl sink with drainer
Model	BEST 480
Base (mm)	600
0	Inset
Dimensions (mm)	1000 x 510
Hole for built-in installation (mm)	980 x 480
Number of Bowls	1
Bowl Depth (mm)	200



0	
Gross Weight (kg)	19,93
Net Weight (kg)	13,80
Packaging Dimension (kg)	1080 x 575 x 300
0 (kg)	0,186

