

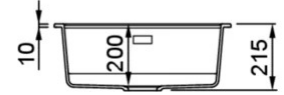

## BEST 50 LB

### Technical Drawing

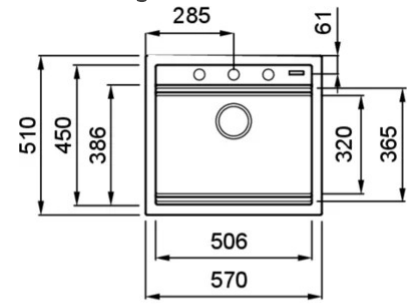

0

**Description** 1-bowl sink

**Model** BEST 105

**Base (mm)** 600

**0** Inset

**Dimensions (mm)** 570 x 510

**Hole for built-in installation (mm)** 550 x 480

**Number of Bowls** 1

**Bowl Depth (mm)** 200



0

**Gross Weight (kg)** 13,60

**Net Weight (kg)** 10,00

**Packaging Dimension (kg)** 690 x 575 x 300

**0 (kg)** 0,119

